

Dependant 4 & 6

Accessories

**louis
poulsen**

Design Louis Poulsen

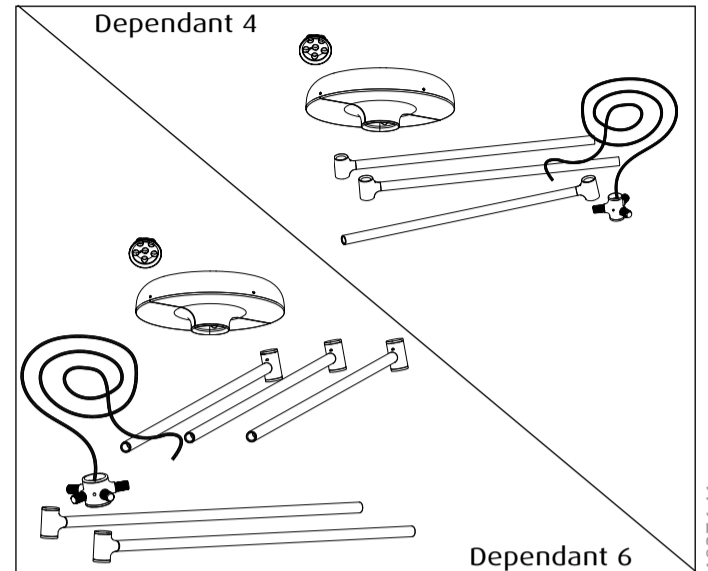
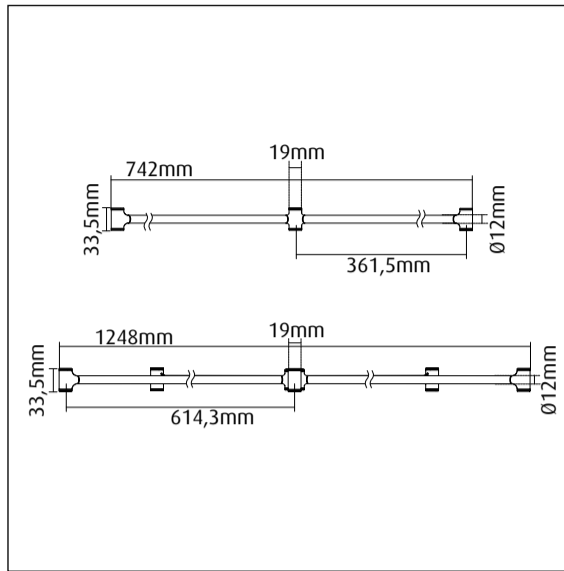
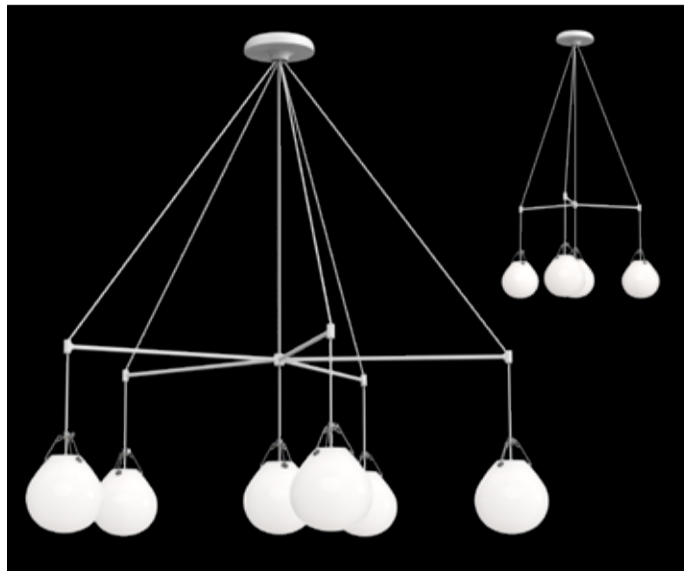

18371-11

Max Effekt Max Wattage Max Wattzahl Max wattal Max potenza Max puissance Max Vataje Max Teho	Spænding/frekvens Voltage/frequency Spannung/frequenz Spänning/frekvens Tensione/frequenza Voltage/frequence Tensión/frecuencia Jännite/taajuus	Vægt Weight Gewicht Vikt Peso/ingombro Poids Peso Paino	Isolationsklasse Electric shock protection Schutzklasse Isolationsklass Classe di isolamento Protection au choc électrique Clase de aislamiento Eristysluokka	Tæthedsklasse Ingress protection Schutzart Kapslingsklass Grado di protezione Indice de protection Clase de protección Kotelointiluokka
Max. 100W per. luminaire	220-240V, 50/60Hz	Dependant 4: 1,0 kg Dependant 6: 1,3 kg	Dependant: Cl. I Both Cl.I and cl.II Pendants are allowed to be hanged in Dependant	IP 20

DA
Støv aftørres med en tør, blød klud. Fedtpletter og lignende kan fjernes med en blød klud opvredet i lunkent vand (<50° C) tilsat mildt rengøringsmiddel.
Brug aldrig rengøringsmidler med slibemiddel eller opløsningsmidler.

EN
Wipe off dust with a dry, soft cloth. Remove greasy spots etc. with a soft cloth dampened in luke-warm water (<50° C) with a mild detergent.
Never use detergents containing abrasives and solvents.

DE
Staub bitte mit einem trockenen, weichen Lappen abwischen. Fettflecke und dgl. mit einem feuchten, in lauwarmem Wasser (<50° C) mit mildem Reinigungsmittel ausgewrungenen Lappen entfernen.
Niemals Reinigungsmittel mit Schleifmittel oder Lösungsmittel verwenden.

SV
Lampan dammtorkas med en torr, mjuk trasa. Fettfläckar tas bort med ljummet vatten (<50° C) utblandat med mildt rengöringsmedel.
Använd aldrig rengöringsmedel som innehåller slipmedel eller lösningsmedel

IT
Pulire la polvere esterna con un panno morbido e asciutto. Rimuovere macchie di grasso ecc. con un panno morbido inumidito in acqua tiepida (<50° C) e con un detergente leggero.
Non usare mai detergenti contenenti abrasivi o solventi.

FR
Essuyez la poussière avec un chiffon sec et doux. Enlevez les points de saleté etc. avec un chiffon doux imprégné d'eau claire tiède et de détergent doux.
Ne jamais utiliser de détergents contenant des abrasifs et des solvants.

ES
Limpiar con paño seco y suave. Quitar manchas de grasa y otras con paño suave humedecido con agua templada (<50° C) con detergente poco agresivo.
Nunca use detergentes que contengan abrasivos y disolventes.

FI
Pyyhi pölyt kuivalla pehmeällä liinalla. Poista rasvatahrat miedolla pesuaineella ja haalealla vedellä (<50° C) kostutetulla pehmeällä liinalla.
Älä koskaan käytä liuottimia tai hankausaineita sisältäviä pesuaineita.

Max weight of Pendant:

Max: 4,99kg per Luminiare

Dependant is for cord hanged pendant only

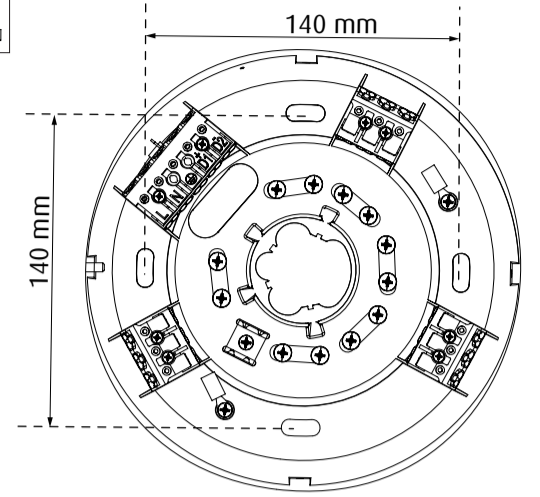
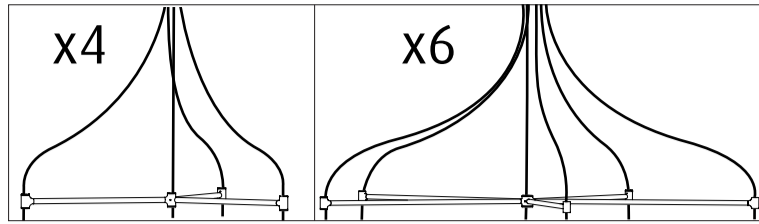
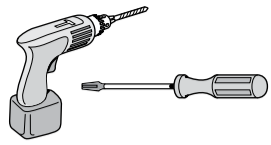
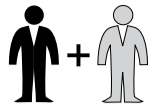
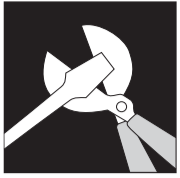

A

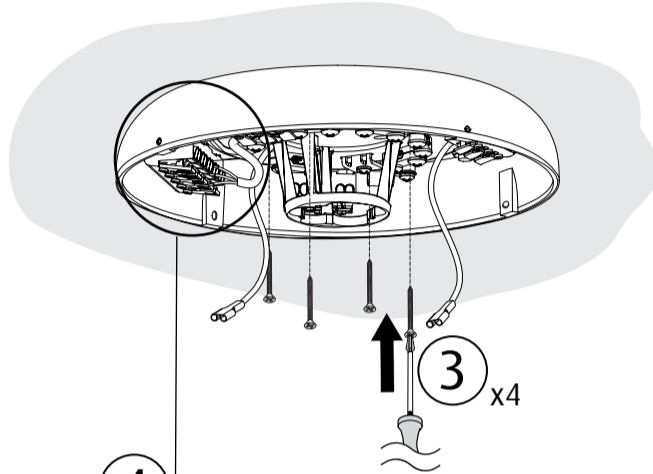
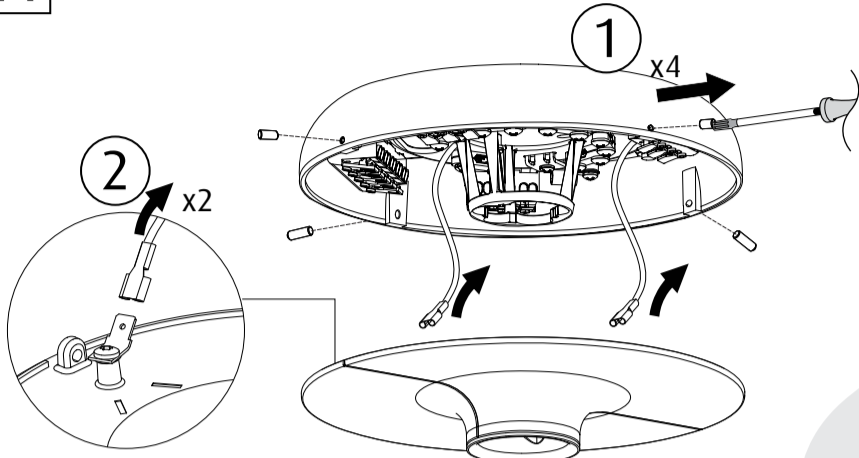

Side mounting for fixed installation

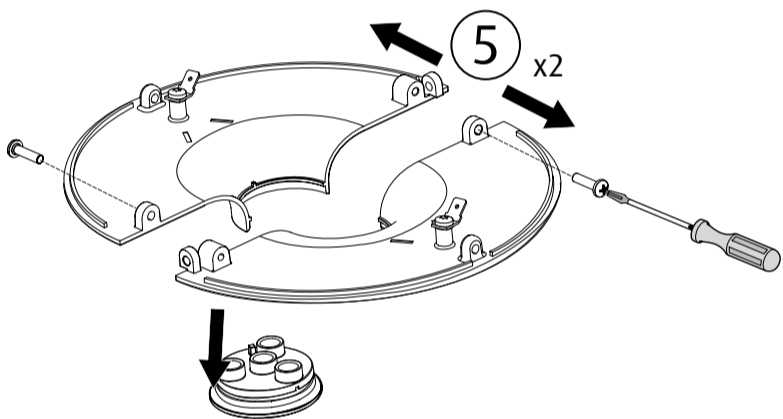
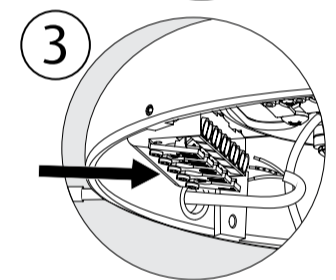
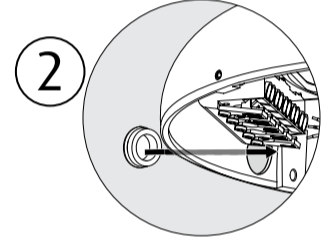
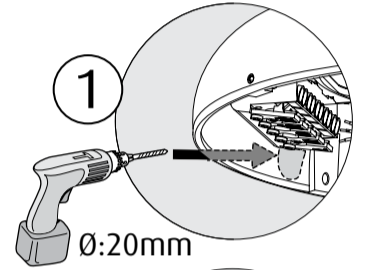

4

	L	N	⊕
DA	Brun	Blå	Gul/Grön
SV	Brun	Blå	Gul/Grön
EN	Brown	Blue	Yellow/Green
DE	Braun	Blau	Gelb/Grün
IT	Marrone	Blu	Giallo/Verde
FR	Brun	Bleu	Jaune/Vert
ES	Marrón	Azul	Amarillo/Verde
FI	Ruskea	Sininen	Keltainen/Vihreä

B

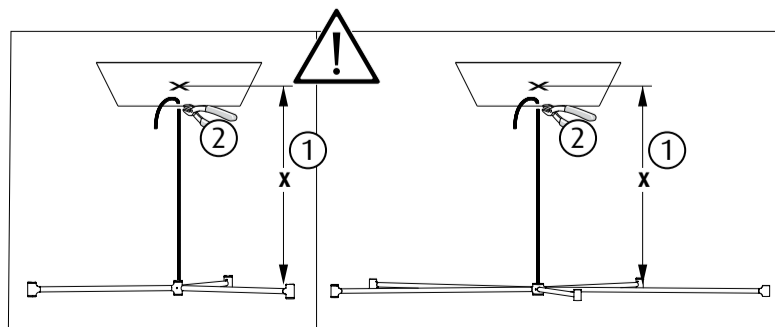
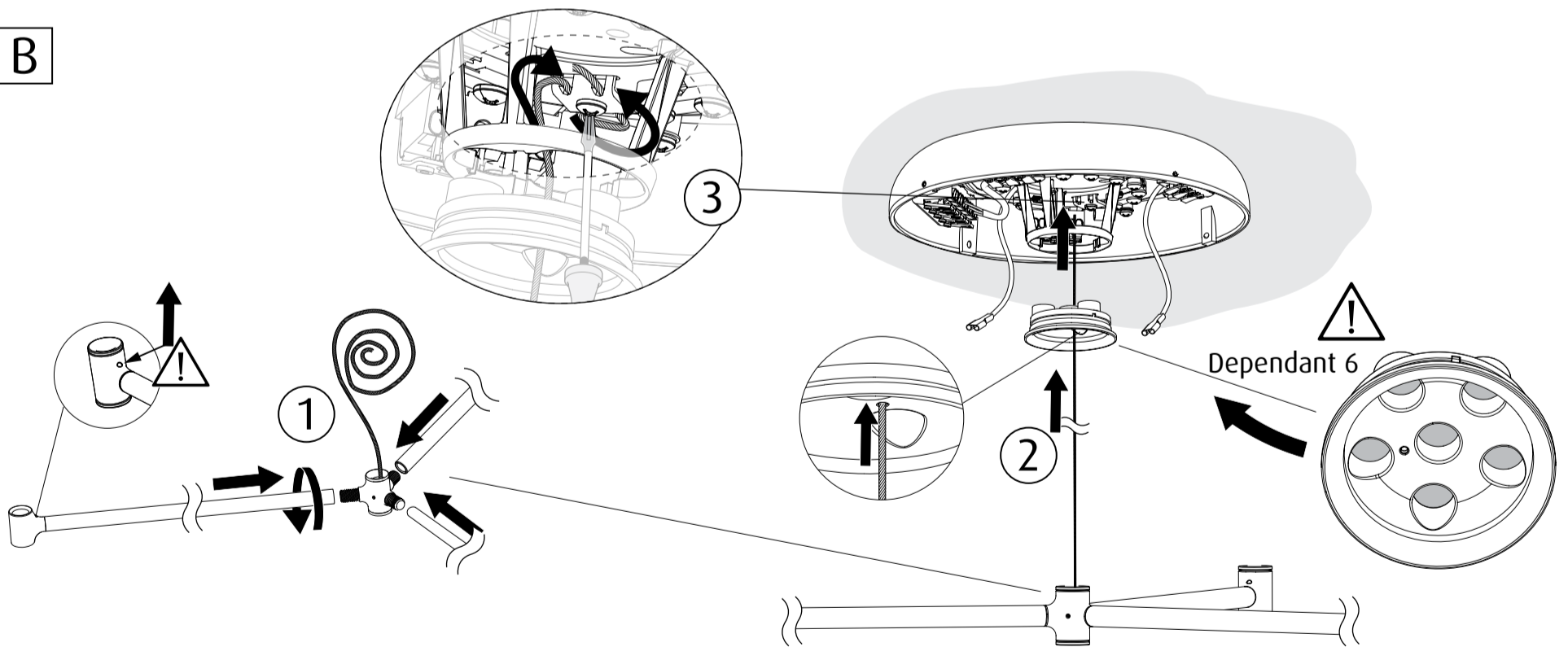

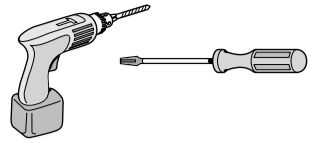
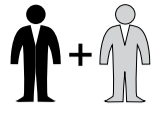
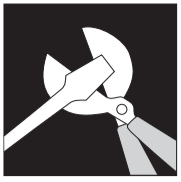

2

	L	N	⊖
DA	Brun	Blå	Gul/Grøn
SV	Brun	Blå	Gul/Grøn
EN	Brown	Blue	Yellow/Green
DE	Braun	Blau	Gelb/Grün
IT	Marrone	Blu	Giallo/Verde
FR	Brun	Bleu	Jaune/Vert
ES	Marrón	Azul	Amarillo/Verde
FI	Ruskea	Sininen	Keltainen/Vihreä



4 = x4
6 = x6

C

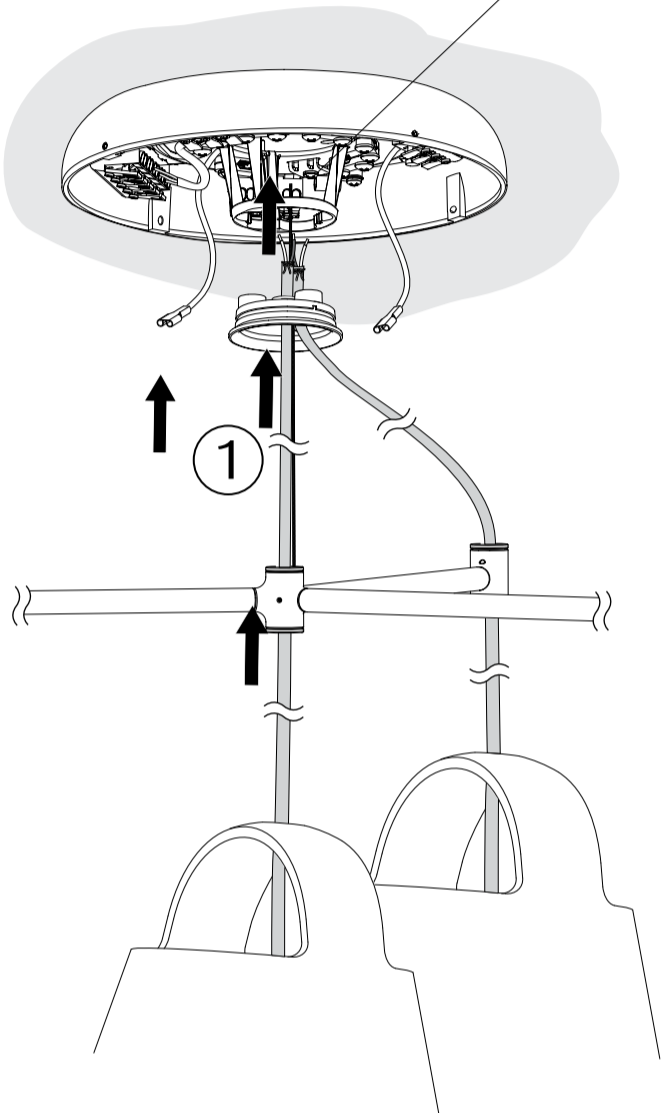
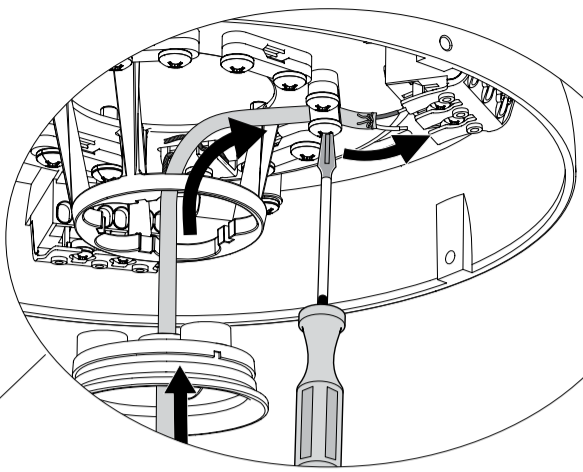

D

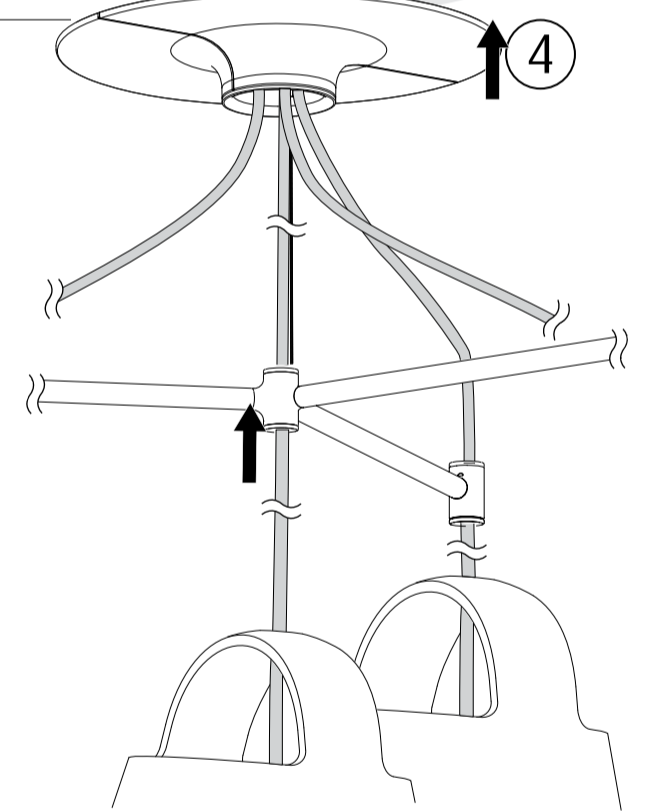
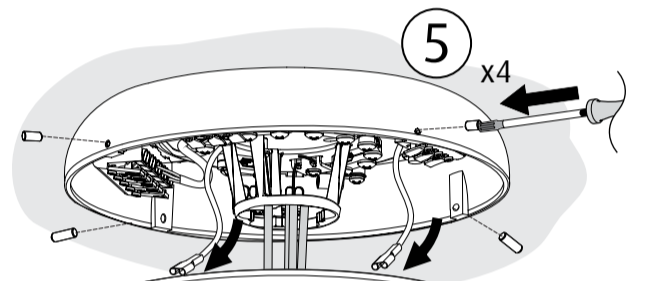
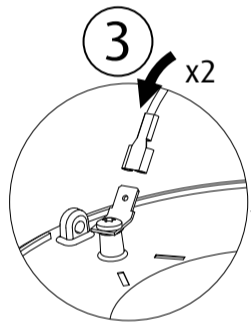
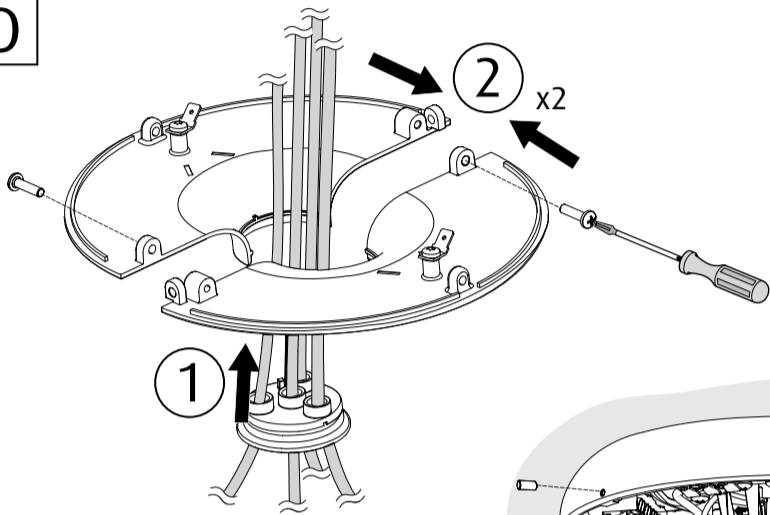

E

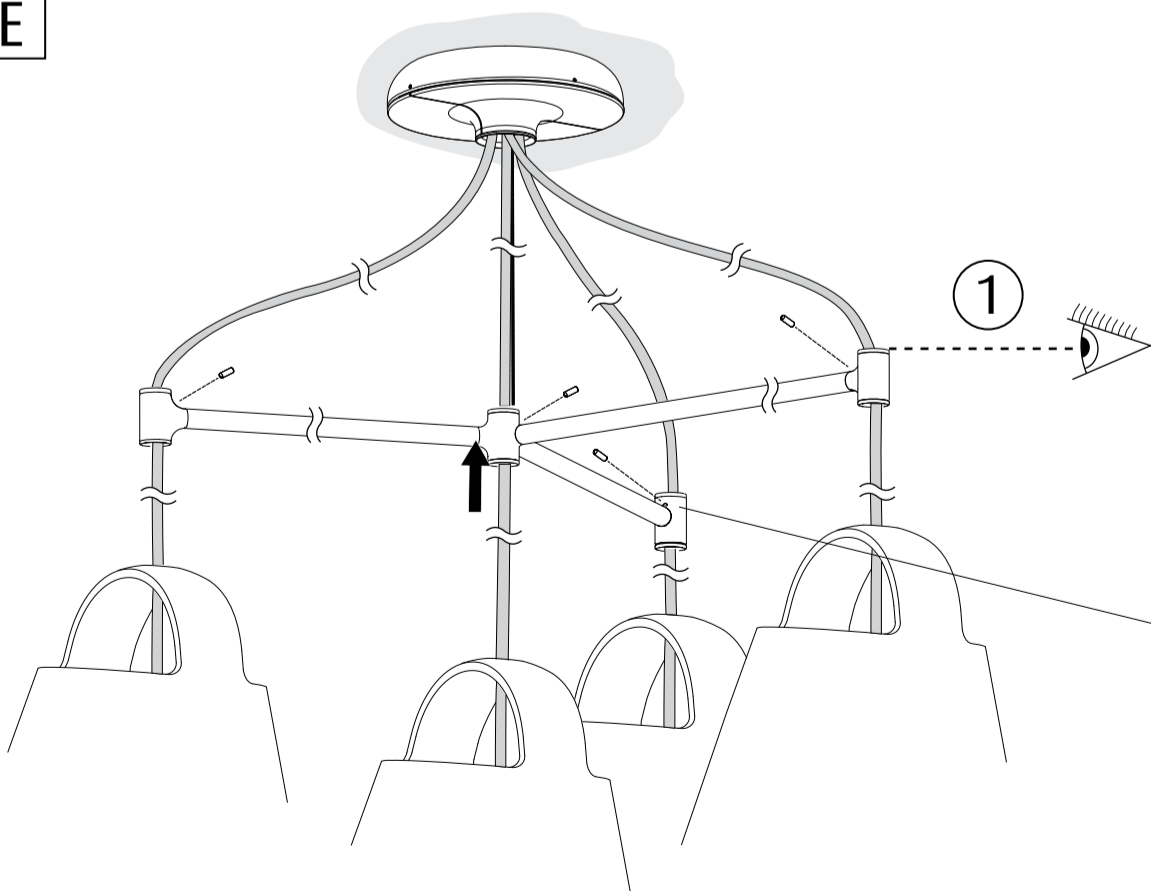

4 = x4
6 = x6

